

BHTS ZZ GR CG 350°

Extreme Temperature Bearings



6000 SERIE

Designation	Bore (B)	Diam (D)	Width (W)	Speed, RPM	Static Load, kN at 350°C	Static Load, kN at 20°C
6000 BHTS ZZ GR CG 350°	10	26	8	90	1,35	1,96
6001 BHTS ZZ GR CG 350°	12	28	8	85	1,63	2,36
6002 BHTS ZZ GR CG 350°	15	32	9	80	1,97	2,85
6003 BHTS ZZ GR CG 350°	17	35	10	75	2,24	3,25
6004 BHTS ZZ GR CG 350°	20	42	12	70	3,45	5,00
6005 BHTS ZZ GR CG 350°	25	47	12	65	4,03	5,85
6006 BHTS ZZ GR CG 350°	30	55	13	60	5,52	8,00
6007 BHTS ZZ GR CG 350°	35	62	14	55	7,17	10,4
6008 BHTS ZZ GR CG 350°	40	68	15	50	8,14	11,8
6009 BHTS ZZ GR CG 350°	45	75	16	45	9,86	14,3
6010 BHTS ZZ GR CG 350°	50	80	16	40	10,76	15,6
6011 BHTS ZZ GR CG 350°	55	90	18	40	14,62	21,2
6012 BHTS ZZ GR CG 350°	60	95	18	40	16,00	23,2
6013 BHTS ZZ GR CG 350°	65	100	18	40	17,24	25,0
6014 BHTS ZZ GR CG 350°	70	110	20	40	21,72	31,5
6015 BHTS ZZ GR CG 350°	75	115	20	40	23,45	34,0

6200 SERIE

Designation	Bore (B)	Diam (D)	Width (W)	Speed, RPM	Static Load, kN at 350°C	Static Load, kN at 20°C
6200 BHTS ZZ GR CG 350°	10	30	9	90	1,79	2,60
6201 BHTS ZZ GR CG 350°	12	32	10	85	2,14	3,10
6202 BHTS ZZ GR CG 350°	15	35	11	80	2,59	3,75
6203 BHTS ZZ GR CG 350°	17	40	12	75	3,27	4,75
6204 BHTS ZZ GR CG 350°	20	47	14	70	4,52	6,55
6205 BHTS ZZ GR CG 350°	25	52	15	65	5,52	8,00
6206 BHTS ZZ GR CG 350°	30	62	16	60	7,72	11,2
6207 BHTS ZZ GR CG 350°	35	72	17	55	10,55	15,3
6208 BHTS ZZ GR CG 350°	40	80	18	50	12,41	18,0
6209 BHTS ZZ GR CG 350°	45	85	19	45	14,06	20,4
6210 BHTS ZZ GR CG 350°	50	90	20	40	16,55	24,0
6211 BHTS ZZ GR CG 350°	55	100	21	40	20,00	29,0
6212 BHTS ZZ GR CG 350°	60	110	22	40	24,83	36,0
6213 BHTS ZZ GR CG 350°	65	120	23	40	28,62	41,5
6214 BHTS ZZ GR CG 350°	70	125	24	40	30,34	44,0
6215 BHTS ZZ GR CG 350°	75	130	25	40	33,79	49,0

6300 SERIE

Designation	Bore (B)	Diam (D)	Width (W)	Speed, RPM	Static Load, kN at 350°C	Static Load, kN at 20°C
6300 BHTS ZZ GR CG 350°	10	35	11	90	2,38	3,45
6301 BHTS ZZ GR CG 350°	12	37	12	85	2,86	4,15
6302 BHTS ZZ GR CG 350°	15	42	13	80	3,72	5,40
6303 BHTS ZZ GR CG 350°	17	47	14	75	4,52	6,55
6304 BHTS ZZ GR CG 350°	20	52	15	70	5,86	8,50
6305 BHTS ZZ GR CG 350°	25	62	17	65	7,86	11,4
6306 BHTS ZZ GR CG 350°	30	72	19	60	11,24	16,3
6307 BHTS ZZ GR CG 350°	35	80	21	55	13,10	19,0
6308 BHTS ZZ GR CG 350°	40	90	23	50	17,24	25,0
6309 BHTS ZZ GR CG 350°	45	100	25	45	22,06	32,0
6310 BHTS ZZ GR CG 350°	50	110	27	40	26,20	38,0
6311 BHTS ZZ GR CG 350°	55	120	29	40	32,76	47,5
6312 BHTS ZZ GR CG 350°	60	130	31	40	35,86	52,0
6313 BHTS ZZ GR CG 350°	65	140	33	40	41,38	60,0
6314 BHTS ZZ GR CG 350°	70	150	35	40	46,90	68,0
6315 BHTS ZZ GR CG 350°	75	160	37	40	52,76	76,5

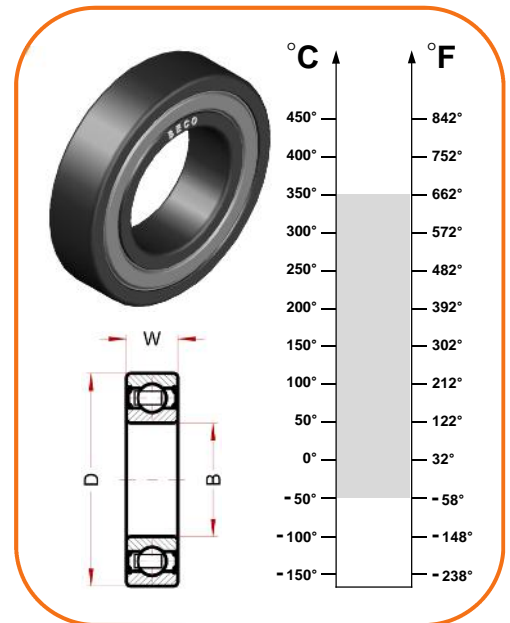

Technical characteristics:

- Bearing material: steel AISI 52100 (Chrome) stabilized to the application
- Treatment of manganese phosphate coating on all steel parts of the bearing
- Radial Clearance 4xC5
- Shields type ZZ
- In one piece graphite cage (coronet cage)

Fields of application:

- Paint Ovens
- Steel industry
- Furnaces for Ceramic Industry
- Trolley Industry, Trolley for Brick Kilns Industry



12100 Cuneo - Italy
Via Volta, 7
phone: 0039 0171 66883
fax: 0039 0171 648913

www.becoitalia.it